

**Installation and Operating Instructions for
Brake EV/EH 018/024/028/038 FEM – 240M/480M**

E 09.767e



RINGSPANN GmbH

Schaberweg 30-38
61348 Bad Homburg
Germany

Phone +49 6172 275 0
Fax +49 6172 275 275

www.ringspann.com
info@ringspann.com

RINGSPANN	Installation and Operating Instructions for Brake EV/EH 018/024/028/038 FEM- 240M/480M Spring activated – electromagnetically released	E 09.767e			
issue: 01.03.2022	version: 3	drawn.: FRMA	checked.: EISF	pages: 25	page: 2

IMPORTANT

Please read these instructions carefully before installing and operating the product. Your particular attention is drawn to the notes on safety.

These installation and operating instructions are valid on condition that the product meets the selection criteria for its proper use. Selection and design of the product is not the subject of these installation and operating instructions.

Disregarding or misinterpreting these installation and operating instructions invalidates any product liability or guarantee by RINGSPANN; the same applies if the product is taken apart or changed.

These installation and operating instructions should be kept in a safe place and should accompany the product if it is passed on to others -either on its own or as part of a machine- to make it accessible to the user.

SAFETY NOTICE

- Installation and operation of this product should only be carried out by skilled personnel.
- Repairs may only be carried out by the manufacturer or accredited RINGSPANN agents.
- If a malfunction is indicated, the product or the machine into which it is installed, should be stopped immediately and either RINGSPANN or an accredited RINGSPANN agent should be informed.
- Switch off the power supply before commencing work on electrical components.
- Rotating machine elements must be protected by the purchaser to prevent accidental contact.
- Supplies abroad are subject to the safety laws prevailing in those countries.

This is a translation of the German original version!

In case of inconsistencies between the German and English version of this installation and operating instruction, the German version shall prevail.

RINGSPANN	Installation and Operating Instructions for Brake EV/EH 018/024/028/038 FEM- 240M/480M Spring activated – electromagnetically released			E 09.767e	
issue: 01.03.2022	version: 3	drawn.: FRMA	checked.: EISF	pages: 25	page: 3

Contents

1. General remarks

- 1.1 General safety instructions
- 1.2 Special safety instructions

2. Function, Markings, Technical Details, Parts list

- 2.1 Function
- 2.2 Markings
- 2.3 Technical details
- 2.4 Drawing and parts list

3. Proper use / specified purpose

4. Improper use

5. Condition upon delivery

6. Handling and storage

7. Technical requirements for safe and reliable operation

8. Installation of the RINGSPANN brake

- 8.1 General instruction for assembly and installation
- 8.2 Prior assembly and installation
- 8.3 Adjust to the brake disc thickness and mounting the brake
- 8.4 Electrical connection
- 8.5 Brake force adjustment
- 8.6 Manual brake release

9. Commissioning

10. Disassembling the brake

11. Maintenance

- 11.1 General maintenance
- 11.2 Brake pad adjustment, permissible brake pad wear and brake pad replacement

12. Accessories: switches

- 12.1 Installing and connecting the inductive proximity switches for brake closed, brake open and brake pad wear adjustment necessary

13. EC-Declaration of Conformity

RINGSPANN	Installation and Operating Instructions for Brake EV/EH 018/024/028/038 FEM- 240M/480M Spring activated – electromagnetically released			E 09.767e	
issue: 01.03.2022	version: 3	drawn.: FRMA	checked.: EISF	pages: 25	page: 4

1. General remarks

1.1 General safety instructions

Please read these installation and operating instructions carefully before installing and operating the brake. Please refer also to the drawings in the various sections.

Safety must be given the highest priority during all work performed on the brake.

Switch off the drive unit before performing work on the brake.

Rotating components (e.g. brake disc) must be secured by the operator to prevent accidental contact.

1.2 Special safety instructions



Danger to life and limb!

It is essential to secure the entire drive train against inadvertent starts during brake installation and maintenance. Rotating components can cause severe injuries.

Therefore, rotating components (e.g. brake disc) must be secured by the operator to prevent accidental contact.

2. Function, Markings, Technical Details, Parts list

2.1 Function

The brakes of type EV an EH are machine components, used for the purpose of braking accelerated masses safely and reliably. The combination of brake and brake disc provides a complete brake unit capable of securing machines and equipment system effectively. Thanks to its universal design, it can perform the following functions:

- As a holding or parking brake, it prevents the unintended start of a stationary shaft.
- As a stopping brake, it brings a rotating shaft to a complete standstill.

Braking force is generated by spring force. The brake is released electromagnetically.

2.2 Markings

These installation and operating instructions apply to:

- the types EV/EH 018/024/028/038 FEM, each with two separate voltage ranges 240V (220 ... 240VAC) and 480V (380 ... 480VAC).
- installation on horizontal brake discs and vertical brake discs in combination with horizontal shafts
- for models with and without switches
- for different brake pad material and for brake pads with signal cables.

On the brake you can find a name plate with a 16 digit material number. Only with that type number you can specify the brake.

Please consult the drawings in each section when using this instructions.

RINGSPANN	Installation and Operating Instructions for Brake EV/EH 018/024/028/038 FEM- 240M/480M Spring activated – electromagnetically released			E 09.767e	
	issue: 01.03.2022	version: 3	drawn.: FRMA	checked.: EISF	pages: 25 page: 5

As well as these instructions, please also consider the catalogue data for the brake at www.ringspann.com and the drawings in the individual sections.

2.3 Technical details

	EV / EH 018FEM	EV / EH 024FEM	EV / EH 028FEM	EV / EH 038FEM
Clamping force	3200 N	5000 N	10000 N	20000 N
Nominal air gap each side	0,3 mm	0,3 mm	0,3 mm	0,3 mm
Max. friction pad wear ²⁾	5 mm	5 mm	7 mm	7 mm
Friction pad wear without adjustment	0,5 mm	0,5 mm	0,5 mm	0,5 mm
Clamping force / braking torque adjustable ¹⁾	50 – 100%	50 – 100%	60 – 100%	60 – 100%
Weight [kg]	6,5 kg	13 kg	24 kg	50 kg
Smallest brake disc diameter	125 mm	250 mm	300 mm	430 mm
Brake disc thickness	type 12,5	8 to 15mm	10 to 16 mm	10 to 16 mm
	type 25	16 to 20 mm	18 to 26 mm	18 to 26 mm
Supply voltage ¹⁾	220 .. 240VAC	220 .. 240VAC	220 .. 240VAC	220 .. 240VAC
	380 .. 480 VAC	380 .. 480 VAC	380 .. 480 VAC	380 .. 480 VAC
Supply voltage frequency ⁴⁾	50 or 60 Hz	50 or 60 Hz	50 or 60 Hz	50 or 60 Hz
Electric fuse	10 A; „B“	10 A; „B“	10 A; „B“	10 A; „B“
Power consumption „brake open“	14 W (220-240V)	20 W (220-240V)	14 W (220-240V)	10 W (220-240V)
	32 W (380-480V)	22 W (380-480V)	19 W (380-480V)	24 W (380-480V)
Electrical degree of protection	IP 65	IP 65	IP 65	IP 65
Insulation class	PE conductor	PE conductor	PE conductor	PE conductor
Duty cycle	100 %	100 %	100 %	100 %
Max. switching frequency at 20°C ambient temperature ³⁾	240 / h	240 / h	240 / h	240 / h
Ambient temperature ^{3) 5)}	-30°C .. +65°C	-30°C .. +65°C	-30°C .. +65°C	-30°C .. +65°C

¹⁾ The nominal value is marked on the type label, and on a sticker on the electronics. There are two kinds of electronics: 220 ... 240VAC and 380 ... 480 VAC.

²⁾ The max. allowable friction pad wear depends on the brake disc thickness. See also chapter 11.2.

³⁾ Higher ambient temperature as 20°C reduces the max. switching frequency per hour. For shorter switching time than 15s consult RINGSPANN.

⁴⁾ No adjustments necessary, the brake can only be used with 50Hz or 60Hz.

⁵⁾ At low temperatures below -30°C to -40°C, a reduction in clamping force is necessary. Consultation with RINGSPANN is necessary.

2.4 Drawing and Parts list

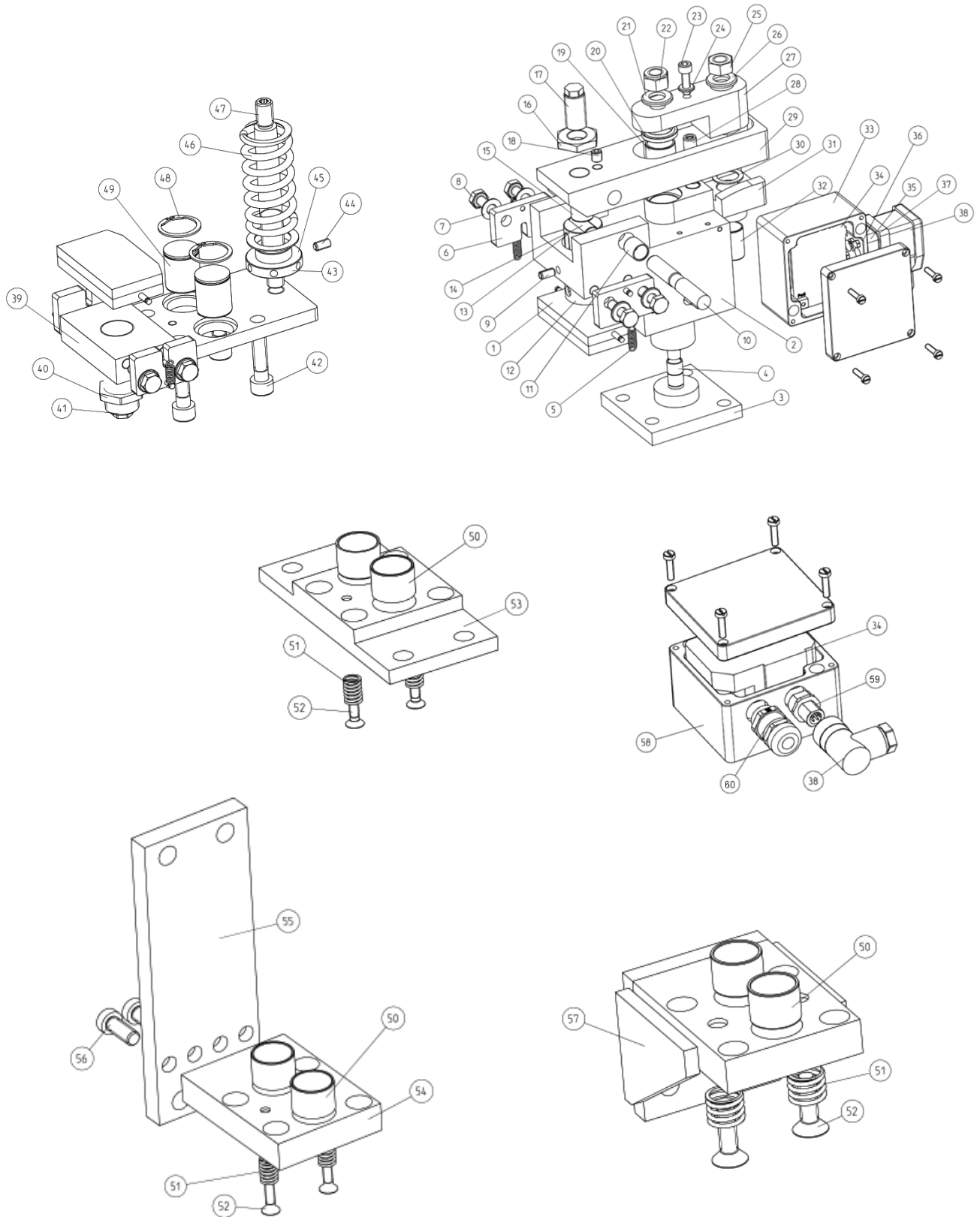

**Information!**

For a clear assignment the 16 digit material number of the brake is necessary.

Part	Nomenclature	Quantity			
		018	024	028	038
1	Set brake pad	1	1	1	1
2	Solenoid housing with coil	1	1	1	1
3	Solenoid lid	1	1	1	1
4	Slide bushing	1	2	2	1
5	Tension spring	4	4	4	4
6	Retaining plate	4	4	4	4
7	Washer DIN125	8	8	8	8
8	Hexagon head screw ISO4017	8	8	8	8
9	Coiled spring pin	1	1	1	1
10	Bearing pin	1	1	1	1
11	Slide bushing	2	2	2	2
12	Slide bushing	1	1	1	1
13	Calotte	1	1	1	1
14	Cylindrical roller DIN5402	1	1	1	1
15	Cylindrical roller DIN5402	1	1	1	1
16	Hexagon nut	1	1	1	1
17	Threaded pin with hexagon head	1	1	1	1
18	Threaded pin	1	1	1	1
19	Slide bushing	1	1	1	1
20	Wiper	1	1	1	1
21	Washer DIN125	1	1	1	1
22	Hexagon nut DIN985	1	1	1	1
23	Hexagon socket head cap screw DIN912	1	1	1	1
24	Washer DIN125	1	1	1	1
25	Hexagon nut DIN934	1	1	1	1
26	Washer DIN125	1	1	1	1
27	Spring compressor	1	1	1	1
28	Dowel pin	1	1	1	1
29	Lever	1	1	1	1
30	Washer	1	1	-	-
31	Lever pressure piece	1	1	1	1
32	Slide bushing	1	1	1	2
33	Electronic housing	-	1	1	1
34	Electronic	1	1	1	1
35	Flange connector	-	1	1	1
36	Gasket, for rectangular connector	-	1	1	1
37	Gasket, for rectangular connector	1	1	1	1

38	Connector	1	1	1	1
39	Base plate	1	1	1	1
40	Hexagon nut	1	1	1	1
41	Threaded pin with hexagon head	1	1	1	1
42	Hexagon socket head cap screw DIN912	4	4	4	4
43	Spring compression nut	1	1	1	1
44	Threaded pin	1	1	1	1
45	Washer	4	4	4	1
46	Compression spring	1	1	1	1
47	Guide rod	1	1	1	1
48	Circlip AV	2	2	2	2
49	Guide rod	2	2	2	2
50	Slide bushing	2	2	2	2
51	Compression spring	2	2	2	2
52	Screw	2	2	2	2
53	Attachment plate V	1	1	1	1
54	Adapter plate H	1	1	-	-
55	Attachment plate H	1	1	-	-
56	Hexagon socket head cap screw DIN6912	3	4	-	-
57	Attachment plate H	-	-	1	1
58	Electronic housing 018	1	-	-	-
59	Socket	1	-	-	-
60	Cable gland	1	-	-	-

3. Proper use / specified purpose

The brake may only be connected within the voltage marked on the type label of the brake.

240VAC = 220 ... 240 VAC

480VAC = 380 ... 480 VAC

With 50 Hz or 60 Hz (no adjustment necessary) and corresponding to the technical details. The electrical connection see chapter 8.4.

The brake is designed for use as a holding/parking brake and/or stopping brake. Other uses are improper and incompatible with the specified purpose. RINGSPANN assumes no liability for damages resulting from improper use. The risk is assumed by the user alone.

4. Improper use

Operating the brake with other supply voltage as specified in the technical details is prohibited. To switch the brake without brake disc is only allowed if the assembly locking nut Pos. 25 in Fig. 5.1 remains on the brake and is loosened not more than 4 mm.

Repeated switching without brake disc and without assembly locking nut can damage the brake. Unauthorized constructive modifications of the brake are similarly prohibited. If the grub screw pos. 44 is provided with sealing wax at the factory, the clamping force on the brake must not be adjusted by the customer!

For damages caused by switching the brake without brake disc or unauthorized constructive modifications RINGSPANN assumes no liability for damages resulting from improper use. The risk is assumed by the user alone.

	<p>Attention!</p> <p>To switch the brake without brake disc is only allowed if the assembly locking nut Pos. 25 and washer Pos. 26 in Fig. 5.1 remains on the brake and the nut is loosened not more than 4 mm.</p>
---	--

5. Condition upon delivery

The brake is tested prior to delivery.

The compression spring for the clamping force is fixed in the open position by the assembly locking nut Pos. 25 in Fig. 5.1.

Size	018	024	028	038
Assembly locking nut	M12	M12	M12	M20

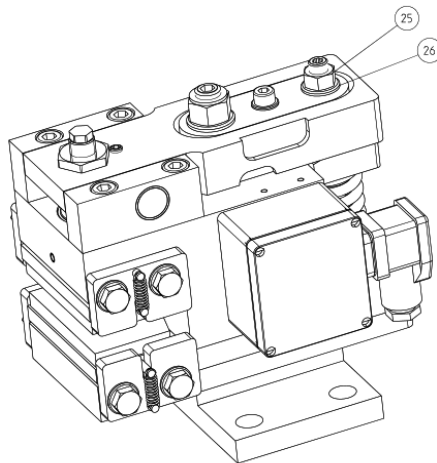

Fig. 5.1

6. Handling and storage

The weight of the brake depends on the size, between 6,5kg and 50kg, see also chapter 2.3. The brake is delivered with anti-corrosion protection and can be stored in an enclosed, dry space for up to 12 months. It is important to prevent condensation from forming. Moist storage areas are unsuitable.

7. Technical requirements for safe and reliable operation

Mounting the brake to stable, low-vibration machine components ensures low-screech, low-noise braking.

RINGSPANN	Installation and Operating Instructions for Brake EV/EH 018/024/028/038 FEM- 240M/480M Spring activated – electromagnetically released			E 09.767e	
issue: 01.03.2022	version: 3	drawn.: FRMA	checked.: EISF	pages: 25	page: 10

To protect the brake electronics, the installation of surge arresters is mandatory. These surge arresters (per phase one) must be connected between the customer's switching relay and the brake electronics. In this case, the surge arrester of L1 and L2 is switched to N or PE in order to derive mains disturbances. For 230 / 400V electric grids e.g., surge protection switch of the brand "Bourns 1250-xS-230" can be used.

8. Installation of the RINGSPANN brake

8.1 General instructions for assembly and installation

Before installing the brake, the brake disc must be cleaned with alcohol, e.g. ethyl or isopropyl alcohol or a water-based surfactant solution (soapy water, etc.) and then rubbed dry with a clean cloth.

When cleaning the brake disc with a thinner, acetone or a brake cleaning agent, it is important to ensure that neither these cleaners nor any cleaner residues come in contact with the brake pads. This is especially important in the case of brakes used only as parking brakes, as no dynamic braking operations take place during which thinner residues would be rubbed off the brake disc.



Please note!

Oil and rust-proofing-agent residues reduced friction coefficient and thus diminish transmissible braking torque substantially!

8.2 Prior assembly and installation

Prior to installation, check to ensure that the mounting surface is even and planned run between the brake disc and the mounting surface is within the tolerance range of 0.2 mm.

Check the axial movement of the brake disc. Axial movement must not exceed ± 0.2 mm.

Maximum permissible lateral brake disc wobble is 0.1 mm. Greater wobble may cause rattling and shaking of the brake unit.



Attention!

Check to ensure that the brake disc rotates freely.

8.3 Adjust the brake to the brake disc thickness and mount the brake

The brake is delivered with a distance between the friction pads of 13,1 or 25,6 mm. You can adjust the distance between the friction pads with the setting screw Pos. 17 and Pos. 41 (see Fig. 8.1 or Fig. 8.2).

The adjustment of the air gap between the friction pads and the brake disc is the same as the adjustment of the brake disc thickness. You can adjust the air gap with the setting screw Pos. 17 and Pos. 41 (see Fig. 8.1 or Fig. 8.2).

The air gap between the friction pad and the brake disc should be **0,3 mm**. A bigger air gap reduces the braking force!

During installation, ensure that the brake pads are centred and in full contact with the surface of the brake disc.

For the distance X and Z see table 8.2 or 8.3. See also Fig. 8.1 or 8.2.

The brake can be hold in position with a lifting belt for the multiple installation positions.

Type	EV018..	EV024..	EV028..	EV038..
Distance X	48 mm	64,5mm	79 mm	103 mm
Distance Z	24,5 mm	19 mm	20 mm	27 mm
Rubbing surface Y	42 mm	47 mm	62 mm	72 mm

Tab. 8.1

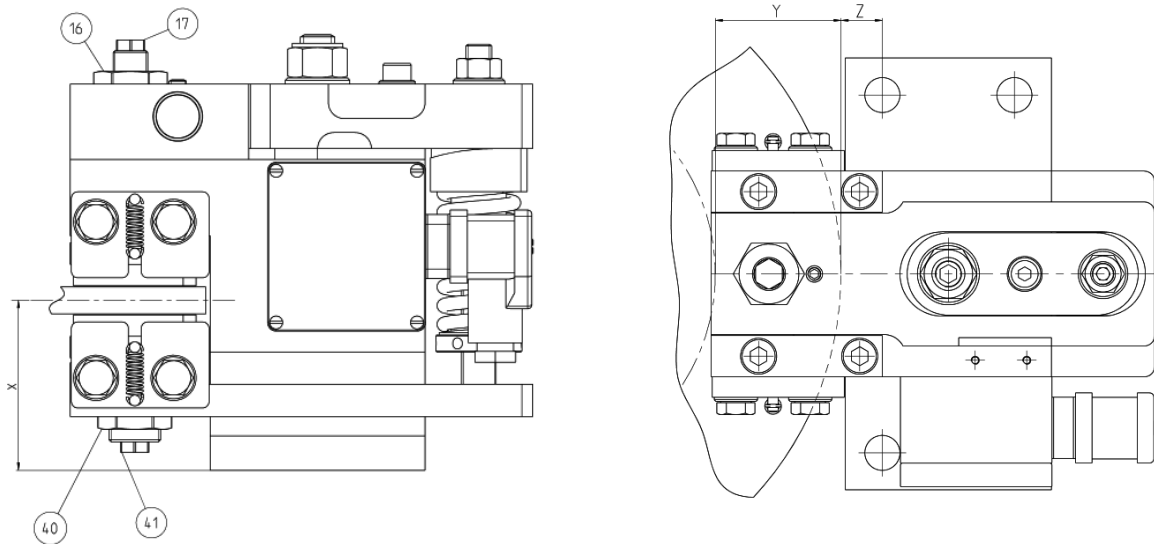

Fig. 8.1 EV....

Type	EH018..	EH024..	EH028..	EH038..
Distance X	60,5 mm	84,5 mm	99 mm	126 mm
Distance Z	24,5 mm	19 mm	22 mm	29,5 mm
Rubbing surface Y	42 mm	47 mm	62 mm	72 mm

Tab. 8.2

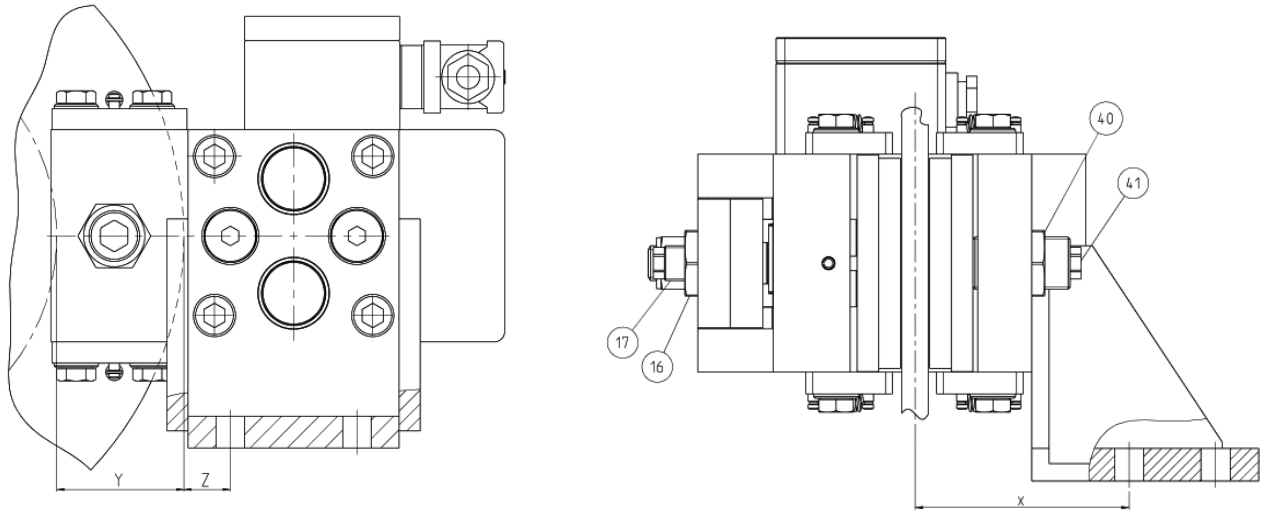

Fig. 8.2 EH.....

The brake is attached with 4 screws. The tightening torques refers to screws lubricated with Molycote MoS2. So the screws must be lubricated with Molycote MoS2.

Size	EV/EH 018	EV/EH024 / EH028	EV028 / EH038	EV038
Screw size	M10-10.9	M12-10.9	M16-10.9	M20-10.9
Tightening torque (lubricated with MoS2)	63 Nm	108 Nm	264 Nm	517 Nm

Tab. 8.3



Information!

To facilitate installation, you may fix the brake in position initially with a single screw before swinging it to the point at which the other screws can be inserted as well.



Attention!

The air gap between brake pad and brake disc is to be adjusted after the first installation and after replacement of brake pads.

After the Adjustment of the air gap the setting screw Pos. 17 and Pos. 41 must be fixed with the nut Pos. 16 and Pos. 40, see Fig. 8.1 or Fig. 8.2.

RINGSPANN	Installation and Operating Instructions for Brake EV/EH 018/024/028/038 FEM- 240M/480M Spring activated – electromagnetically released	E 09.767e
issue: 01.03.2022	version: 3	drawn.: FRMA checked.: EISF pages: 25 page: 13

8.4 Electrical Connection

Attention!



To protect the brake electronics, the installation of surge arresters is mandatory. These surge arresters (per phase one) must be connected between the customer's switching relay and the brake electronics. In this case, the surge arrester of L1 and L2 is switched to N or PE in order to derive mains disturbances. For 230 / 400V electric grids e.g., surge protection switch of the brand "Bourns 1250-xS-230" can be used. In 480 V mains, overvoltage circuit breaker type "Bourns 1250-2S-400" can be used.

Attention!



To protect the electronic against too fast switching, a security feature is integrated in the electronic. The security feature locks the supply voltage and the brake cannot be opened. After 40 s the electronic will pass the supply voltage and after a further activation the brake will open.

Attention!



Only trained electrician are allowed to connect the brake with the supply voltage. The trained electrician must be familiar with the relevant standards (e.g. in Germany DIN VDE 0113).

Attention!



To use the brake the electronic Pos. 34 (included in the scope of delivery) is mandatory. Do not connect the brake directly to the supply voltage.

Attention!



To switch the brake without brake disc is only allowed if the assembly locking nut Pos. 25 in Fig. 5.1 remains on the brake and is loosened not more than 4 mm.

Attention!



For higher operating cycles (> 100 / h), the brake can heat up to 65 ° C.

The following rules must be observed:

- a) It is not allowed to use coiled cables in the supply line. (e.g. cable drum, reserve cable loops or the like)
- b) For safe operation of the brake a sufficient grid quality is necessary. See also the standards of grid quality.
- c) Before replacing the electronic, check the coil of the solenoid to be shure that the coil is not damaged. Please consult RINGSPANN.

Size 024, 028 and 038

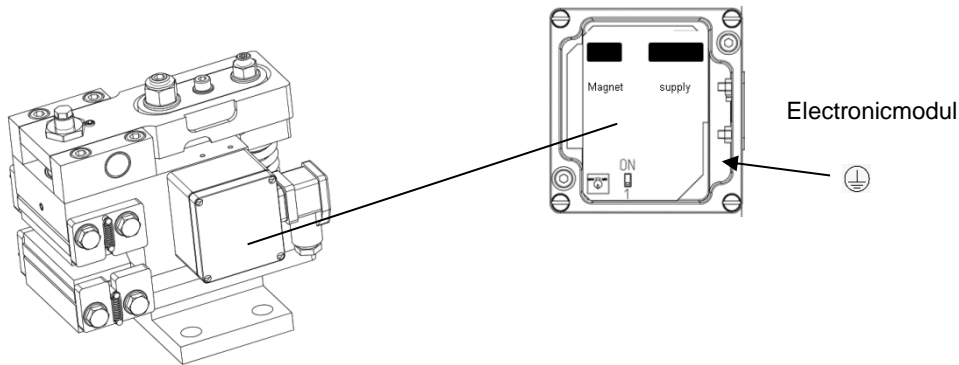
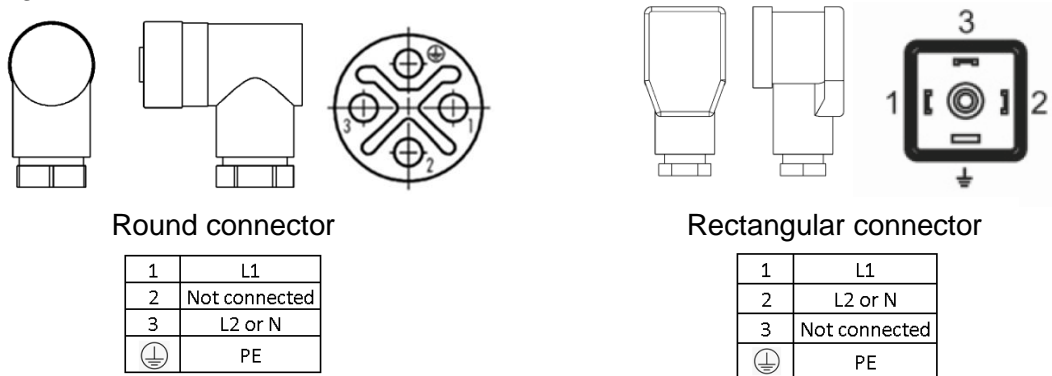

Fig. 8.3

The brake can only be used with 50Hz or 60Hz, no adjustment is necessary.

Supply Voltage : voltage range mentioned on the type label

Contact assignment:



- Degree of protection : IP 65
- Electrical fuse : 10 A, type "B"
- Supply cable : 1,5 .. 2,5 mm² flexible, do not lay the supply cable together with other electrical motors in one cable duct. Use surge arresters!
- Switching function : directly on the operating voltage – double pole switching!
- Switching device : Inrush current 10 A (rms) for 0,2s, than smaller 1 A (rms)

After the electrical connection you have to check the protective earth conductor function (according DIN VDE 0113 or EN 60204).

For the size **018** a separate electronic module is to be used. The electrical connection at the brake is done via a cable gland. For the connection between the brake and the electronic module a cable gland is also used. To connect the supply voltage to the electronic module a connector is to be used. All the plugs are in the scope of delivery.



Attention - SIZE 018 !!

Do not disconnect the cable between the brake and the electronics while the brake is under voltage, **this will destroy the solenoid!**



Attention!

To protect the electronic against too fast switching, a security feature is integrated in the electronic. The security feature locks the supply voltage and the brake cannot be opened. After 40 s the electronic will pass the supply voltage and after a further activation the brake will open.

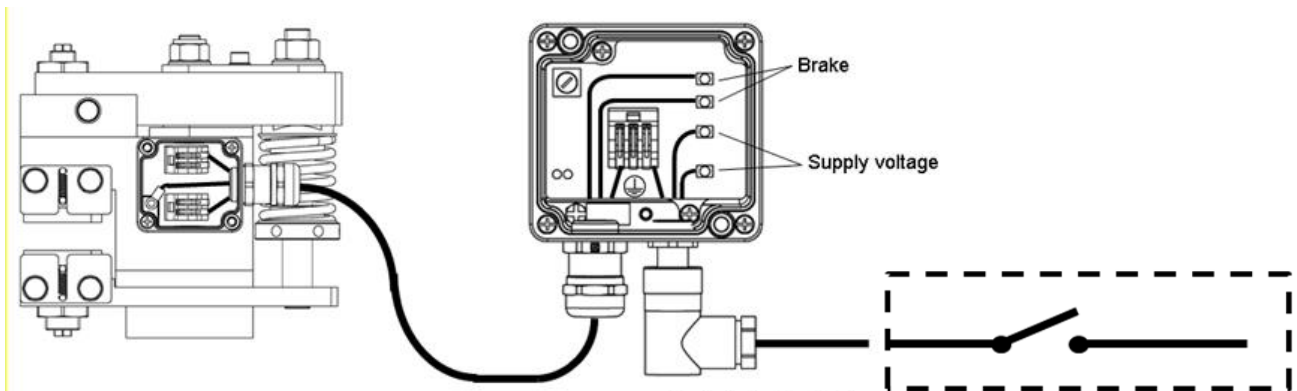



Fig. 8. 4

Contact assignment round connector:



1	L1
2	Not connected
3	L2 or N
	PE

The electronics is automatic frequency adjusted. The brake can only be used with 50Hz or 60Hz.

- Supply Voltage : voltage range mentioned on the type label
- Degree of protection : IP 65, gasket necessary (in the scope of delivery).
- Electrical fuse : 10 A, "B"
- supply cable : 1,5 .. 2,5 mm², not longer than 50m; do not lay the supply cable together with other electrical motors in one cable duct. Use surge arresters!

RINGSPANN	Installation and Operating Instructions for Brake EV/EH 018/024/028/038 FEM- 240M/480M Spring activated – electromagnetically released			E 09.767e	
issue: 01.03.2022	version: 3	drawn.: FRMA	checked.: EISF	pages: 25	page: 16

cable between brake and electronics : 1,5 .. 2,5mm² flexibel, no longer than 3m.

Switching function : directly on the operating voltage (**not between the electronics and the brake!**)– double pole switching!

Switching device : Inrush current 5 A (rms) for 0,2 s, than smaller 1 A (rms)

After the electrical connection you have to check the protective earth conductor function (according DIN VDE 0113 or EN 60204).

8.5 Braking force adjustment

The entire surface of both brake pads must be in contact with the brake disc in order to achieve the optimum braking effect. The brake pads must also be heated briefly to approx. 200°C. Therefore, multiple brief braking operations under low spring force and rotating brake disc are required to heat the brake pads.



Attention!

If the brake is used as parking brake, the brake torques specified are not met. Reductions of up to 50% of the braking torques are possible.



Attention!

If the grub screw pos. 44 is provided with sealing wax at the factory, the clamping force on the brake must not be adjusted by the customer!



Attention!

If the brake cannot be run in, the braking torques listed in our publication no. 46 cannot be achieved. Reductions of up to 50% are possible.

The brakes are preset and delivered with a nominal clamping force. This is also the maximum clamping force. If you want to reduce the clamping force, you have to reduce the spring force. Therefore you have to loosen the threaded pin Pos. 44 of the spring compression nut Pos. 43. With the spring compression nut you can adjust the distance S (see Fig. 8.5) according to the values in table 8.3. Before locking the spring compression nut, turn the nut clockwise and anti clockwise to reduce the torsion of the spring. If you reduce the clamping force the reaction time of the brake will increase. After the adjustment, lock the spring compression nut with the threaded pin.

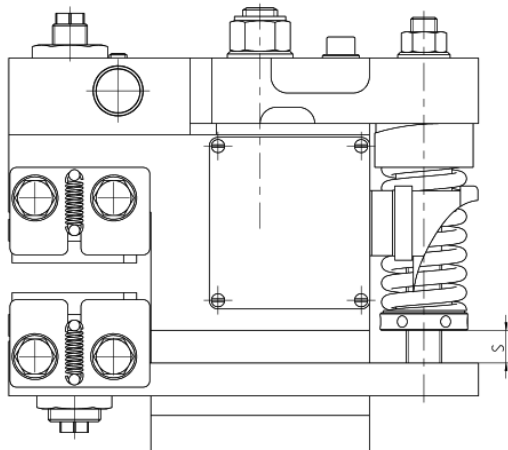

Fig. 8.5

	EV / EH 018	EV / EH 024	EV / EH 028	EV / EH 038
Nominal clamping force (100%) [N]	3200	5000	10000	20000
¹⁾ Braking force [N]	2560	4000	8000	16000
Friction diameter [mm] $D_R =$	$D_A - 46$	$D_A - 51$	$D_A - 66$	$D_A - 76$
¹⁾²⁾ Braking torque [Nm] at $D_A = 200$	200	-	-	-
$D_A = 250$	260	400	-	-
$D_A = 300$	330	500	940	-
$D_A = 355$	400	610	1160	-
$D_A = 430$	490	760	1460	2830
$D_A = 520$	610	940	1820	3550
$D_A = 630$	750	1160	2260	4430
$D_A = 710$	850	1320	2580	5070
Clamping force, adjustable [%]	50-100	50-100	60-100	60-100
³⁾ Distance S [mm]	25	28,5	14,5	27
Loss in Braking Force per mm spring preload reduction [N]	75	165	250	400

¹⁾ Braking force and braking torque is calculated with a theoretical friction coefficient of 0,4 and 100% clamping force.

²⁾ D_A = Outer diameter of the brake disc in mm.

³⁾ With the distance S, 100% clamping force is achieved. With S = 0 mm the smallest adjustable clamping force is achieved.

Tab. 8.4

8.6 Manual brake release

For manual brake release you can use the assembly locking nut Pos. 25 and washer Pos. 26 see Fig. 5.1. To open the brake screw on the nut.

9. Commissioning

RINGSPANN	Installation and Operating Instructions for Brake EV/EH 018/024/028/038 FEM- 240M/480M Spring activated – electromagnetically released		E 09.767e	
issue: 01.03.2022	version: 3	drawn.: FRMA	checked.: EISF	pages: 25 page: 18



Attention!

To switch the brake without brake disc is only allowed, if the assembly locking nut Pos. 25 in Fig. 5.1 remains on the brake and is loosened not more than 4 mm.

Before commissioning you have to switch on the electric current (the solenoid holds the brake open) and the assembly locking nut Pos. 25, Fig. 5.1 is to be removed.
The brake is now ready for operation.

10. Disassembling the brake



Danger to life and limb!

When disassembling the brake it is essential to ensure that the entire drive train is secured against inadvertent activation. Rotating components can cause severe injuries. Therefore, rotating components (e.g. brake discs) must be secured against accidental contact. To prevent injuries to personnel, secure the brake with the aid of an assembly locking device.



Attention - SIZE 018 !!

Do not disconnect the cable between the electronics and the brake while the brake is under voltage, **this will destroy the solenoid!**

Secure the open position with the assembly locking nut Pos. 25 and washer Pos. 26 in Fig. 5.1. Therefore you have to switch on the electric current.
After the brake is secured with the assembly locking nut in open position switch off the electric current.



Attention!

Take care, that the electric supply cable is currentless.

Remove the plug Pos. 38 from the brake.



Attention!

Secure the brake for disassembly

Remove the screws used to hold the brake in place. The brake can now removed from the mounting surface.

RINGSPANN	Installation and Operating Instructions for Brake EV/EH 018/024/028/038 FEM- 240M/480M Spring activated – electromagnetically released			E 09.767e	
issue: 01.03.2022	version: 3	drawn.: FRMA	checked.: EISF	pages: 25	page: 19

11. Maintenance

11.1 General maintenance

Maintenance must be performed on the brake at intervals of 4 weeks up to once a year, depending upon the operating load.

Perform the following checks during every maintenance operation:

- Check brake pads for wear.
- Check the bolt connection between the brake pad and the machine component as well as the bolt connections for the retaining plates for tightness.
- Check the electric supply cables (sight check)

11.2 Brake pad adjustment, permissible brake pad wear and brake pad replacement



Danger to life and limb!

Brake pads may be replaced only when the equipment system and/or the working machine is at a complete standstill!



Attention!

Brake pads must not be worn to a residual thickness (mounting plate thickness plus remaining pad material). Brake pads must always be replaced in pairs.

Only original RINGSPANN brake pads may be used

Brake pad wear adjustment:

To counter brake pad wear you can adjust the distance between brake pad and brake disc with set screws Pos. 41 and Pos. 17 (see Fig. 8.1 or 8.2). Therefore you have to switch on the electric current and screw on the assembly locking nut Pos. 25 in Fig. 5.1. Screw on the assembly locking nut without tightening torque, only with hands. The gap between brake disc and brake pad on each side should be 0,3 mm. The maximum allowable distance between brake disk and brake pad without adjustment is 0,6mm. A greater gap will reduce braking force up to a complete loss of braking force.

A greater gap will reduce braking force. Consider the maximum permissible wear of the brake pads (see table 11.1).

After the adjustment of the gap between brake disc and brake pad, lock the set screw Pos. 41 and Pos. 17 with the locking nut Pos. 16 and Pos. 40.)

Remove the assembly locking nut Pos. 25, Fig. 5.1 The brake is now ready for operation again.



Attention!

The gap between brake disc and brake pad on each side should be 0,3 mm. A greater gap will reduce braking force. The maximum allowable distance between brake disk and brake pad without adjustment is 0,6mm. A greater gap will reduce braking force up to a complete loss of braking force. Consider the maximum permissible wear of the brake pads (see table 11.1).

Size 018	Residual thickness ¹⁾
Brake disc thickness from 8 ... 11mm and 16 ... 17 mm	9 mm
Brake disc thickness from >11 ... 15 mm and >17 ... 20 mm	7 mm

Size 024	Residual thickness ¹⁾
Brake disc thickness 10mm and 18 ... 19 mm	13 mm
Brake disc thickness from >10 ... 16 mm and >19 ... 26 mm	11 mm

Size 028	Residual thickness ¹⁾
Brake disc thickness 10mm and 18 ... 19 mm	17 mm
Brake disc thickness from >10 ... 16 mm and >19 ... 26 mm	13 mm

Size 038	Residual thickness ¹⁾
Brake disc thickness from 22 ... 23 mm	17 mm
Brake disc thickness from 12,5 ... 20 mm and >23 ... 30 mm	15 mm

¹⁾ Residual thickness = backplate of the brake pad + residual brake pad

Tab. 11.1

Brake pad replacement:

Before replacing the brake pads Pos. 1, ensure that the mass held by the brake is secured to prevent movement, as parts of the brake must be loosened/removed for replacement.

Before replacing the brake pads switch on the electric current (the solenoid opens the brake) and secure the the brake with the assembly locking nut Pos. 25 and washer Pos.26 (see Fig. 5.1).

Switch off the electric current.

Remove all tension springs Pos.5 and one of two retaining plates Pos. 6 each side, see Fig. 11.1

Pull out the old brake pads and screw out the set screws Pos. 17 and Pos. 41, Fig. 8.1, so that the new brake pads can easily inserted. Take care, that the chamfer on the brake pad is on the outer diameter of the brake disc and the friction material of the brake pad is on the brake disc side. Fasten the retaining plates again (tightening torque, see table 11.1).

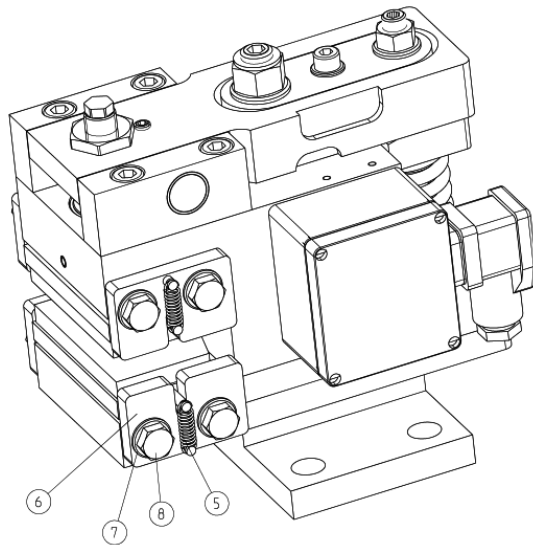

Fig. 11.1

	Size 018	Size 024	Size 028	Size 038
Screw	M6-8.8	M8-8.8	M10-8.8	M12-8.8
Tightening torques ¹⁾	11 Nm	27 Nm	54 Nm	93 Nm

1) Screw secured with Loctite 243.

Tab. 11.2

After replacing the brake pads, you have to adjust the air gap between the brake disc and the brake pad See (chapter 11.2). After replacing the brake pads remember the chapter 8.5. The entire surface of both brake pads must be in contact with the brake disc in order to achieve the optimum braking effect. The brake pads must also be heated briefly to approx. 200°C. Therefore, multiple brief braking operations under low spring force and rotating brake disc are required to heat the brake pads.

12. Accessories: switches for brake closed, brake open and brake pad wear adjustment Necessary (Option)

12.1 Installing and connecting the inductive proximity switches for brake closed, brake open and brake pad wear adjustment necessary



Danger to life and limb!

The inductive proximity switch may be installed and/or replaced only when the equipment system and/or working machine is at a complete standstill!



Danger!

When switching the brake, the lever Pos. 29 and the spring compressor Pos. 27 will move very fast.

The inductive proximity switch must only be mounted and adjusted after the brake has been adjusted (chapter 8).

The assembly of the inductive proximity switch is only possible after the brake is assembled and the air gap between brake pad and brake disc is set correctly (see chapter 8 and 9).

To indicate „Brake open“, „Brake closed“ or “Brake pad adjustment necessary” a inductive proximity switch for each request is to assemble.

The inductive proximity switch is part of the sensor kit and supplied loose as accessory. The sensor kit consists of an inductive proximity switch with two fastening nuts, a fastening sheet metal and fastening screws and washers.

On the brake housing you can find threads to fasten the fastening sheet metal (see Fig. 12.1). On the metal sheet you have different assembling possibilities for “Brake open”, “Brake closed” and “Brake pad wear adjustment necessary” (see Tab. 12.1). You always get a signal for brake status. With one sensor kit you can detect only one brake status, for further signals you have to order another proximity switch in NC or NO version (see picture 12.2; 12.3 and 12.4). For sensor kits with more than one sensor or for special requirements, such as other voltage ranges or low temperatures below -25°C, please contact RINGSPANN.

Sensor kit:

size 018	Brake open (NC) 3500-112005-000000	Brake closed (NO) 3500-112004-000000	Adjust brake pad wear (NO) 3500-112004-000000
size 024	Brake open (NC) 3500-112005-000000	Brake closed (NO) 3500-112004-000000	Adjust brake pad wear (NO) 3500-112004-000000
size 028	Brake open (NO) 3500-112002-000000	Brake closed (NO) 3500-112002-000000	Adjust brake pad wear (NO) 3500-112002-000000
size 038	Brake open (NO) 3500-112003-000000	Brake closed (NO) 3500-112003-000000	Adjust brake pad wear (NO) 3500-112003-000000

Tab.12.1

To adjust the inductive proximity switch for brake pad wear, you can increase the airgap between brake disc and brake pad on each side to a value of 0,6mm. Then switch off the brake (brake is closed). Then fasten the inductive proximity switch in a way that the LED is almost glowing. Then reduce the airgap to 0,3mm again. Switch on the brake, the LED must not glow after the brake is in open position.

Test the proper function by switching the brake. The LED of the proximity switch must glow, if the brake status you want to detect is reached.

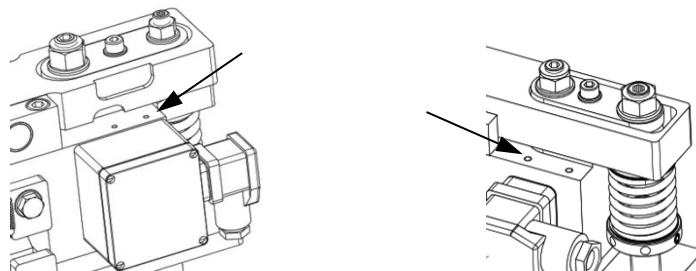

Fig. 12.1

Brake status indication size 018 and 024:

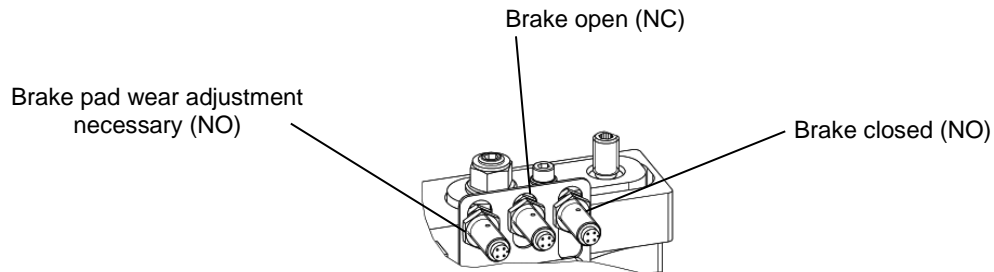

Fig. 12.2

Brake status indication size 028:

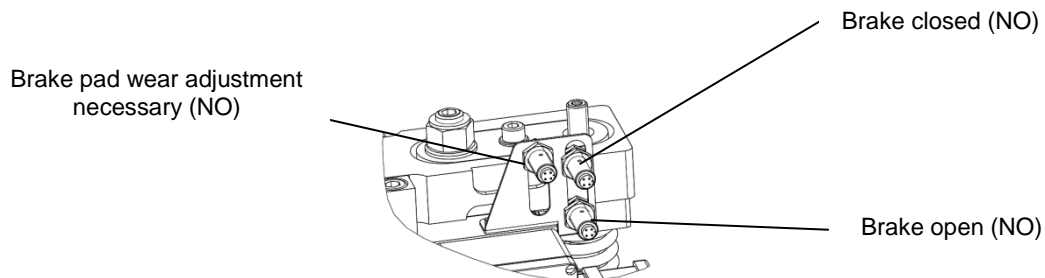

Fig. 12.3

Brake status indication size 038:

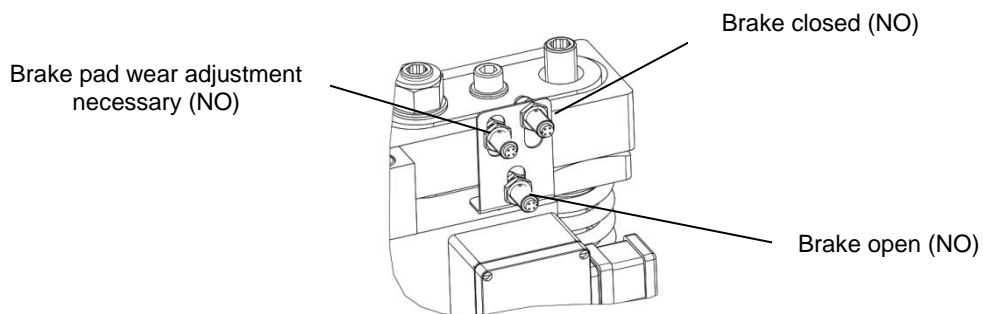

Fig. 12.4

Technical details of the inductive proximity switch:

For inductive proximity switch 3504-000070-000000:

Switching function	: PNP (Closer, NO)	Sensing range	: 4 mm, non-flush
Operating voltage	: 10....36 V DC	Current rating	: 150 mA
Current consumption	: < or = 15 mA	Voltage drop	: < 2,5 V
Polarity protect	: yes	Status indication LED:	yellow
Housing	: brass, coated	Protection	: IP 67
Connection	: M12 connector	Ambient temperature:	-25°C bis +80°C
Short-circuit protection	: yes, pulsed		

RINGSPANN	Installation and Operating Instructions for Brake EV/EH 018/024/028/038 FEM- 240M/480M Spring activated – electromagnetically released	E 09.767e
issue: 01.03.2022	version: 3	drawn.: FRMA checked.: EISF pages: 25 page: 24

Wiring

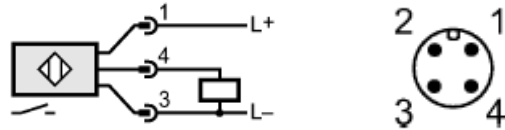

For inductive proximity switch 3504-000071-000000:

Switching function	: NPN (Opener, NC)	Sensing range	: 4 mm, flush
Operating voltage	: 10....30 V DC	Current rating	: 100 mA
Current consumption	: < or = 10 mA	Voltage drop	: < 2,5 V
Polarity protect	: yes	Status indication LED:	yellow
Housing	: brass, coated	Protection	: IP 68
Connection	: M12 connector	Ambient temperature:	-40°C bis +85°C
Short-circuit protection	: yes, snapping		

Wiring

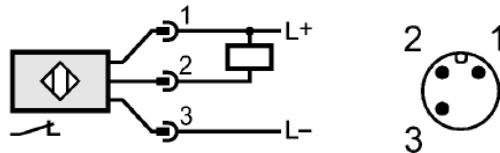

Option:

For inductive proximity switch 3504-000099-000000:

Switching function	: PNP (Opener, NC)	Sensing range	: 4 mm, non- flush
Operating voltage	: 10....36 V DC	Current rating	: 150 mA
Current consumption	: < or = 15 mA	Voltage drop	: < 2,5 V
Polarity protect	: yes	Status indication LED:	yellow
Housing	: brass, coated	Protection	: IP 67
Connection	: M12 connector	Ambient temperature:	-25°C bis +80°C
Short-circuit protection	: yes, pulsed		

Wiring:

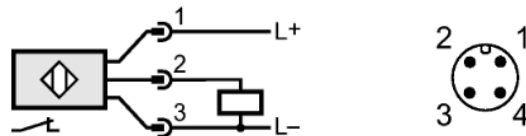

Option:

For inductive proximity switch 3504-000100-000000:

Switching function	: PNP (Closer, NO)	Sensing range	: 4 mm, non-flush
Operating voltage	: 9....32 V DC	Current rating	: 150 mA
Current consumption	: < or = 15 mA	Voltage drop	: < 2,5 V
Polarity protect	: yes	Status indication LED:	yellow
Housing	: brass, coated	Protection	: IP 67
Connection	: M12 connector	Ambient temperature:	-40°C bis +80°C
Short-circuit protection	: yes, pulsed		

RINGSPANN	Installation and Operating Instructions for Brake EV/EH 018/024/028/038 FEM- 240M/480M Spring activated – electromagnetically released		E 09.767e	
issue: 01.03.2022	version: 3	drawn.: FRMA	checked.: EISF	pages: 25 page: 25

13 EC-Declaration of Conformity

Note regarding EMC Directive 2014/30/EU

The brake is an uncritical equipment according to the EMC-Directive because of its passive operation. The brake can not be operated independently. After integration into a complete system, the brake can be evaluated according to EMC-Directive. To comply with DIN EN 61000-6-4, the mounting of a line filter is required as a general rule.

Note regarding EC-Machinery Directive 2009/42/EC

The product is a component for installation in a machine according to the EC-Machinery Directive 2009/42/EC. Together with other components, the product can meet safety-related applications. The necessary measures will emerge from the risk analysis of the machine. Built-in, the brake is part of the machine and the machine manufacturer assesses the conformity of the safety device on the Machinery Directive. The commissioning of the brake is only permitted if the machine fulfills the Machine Directive.

Note regarding REACH Directive No. 1907/2006

The brake is considered as a "product" and not as a "substance", and as such are not subjected to registration.

EC-Declaration of Conformity

For the purpose of EC-Low voltage directive 2014/35/EU

We hereby declare that the following products, developed, designed and manufactured by our own responsibility, are in accordance with the EC-Low voltage directive 2014/35 / EU

RINGSPANN GmbH
Schaberweg 30-38
D-61348 Bad Homburg

Product: Electromagnetic released, spring activated brake disc
Designation: EV/EH..FEM
Sizes: 018/024/028/038
Types: 4453-xxxxxx-xxxxxx

Following standards and directives have been applied and complied with:

Directive		Standard
2014/35/EU	Low Voltage Directive	
2014/30/EU	EMC Directive	DIN EN 61000-6-2
No. 1907/2006	REACH Directive	
2011/65/EU	RoHS Directive	

The commissioning of the brake is only permitted when the machine complies with the EC-Machinery Directive 2006/42 / EC.

ppa. Ernst Fritzeimer

RINGSPANN GmbH
Schaberweg 30-38
D-61348 Bad Homburg

Bad Homburg, 27.10.2016