

Brake Caliper DT 250 FEA ... ST

spring activated – electrohydraulically released
 Drum Brake according to DIN 15 435



Features	Code
Brake Caliper	D
Drum Brake	T
Frame size 250	250
Spring activated	F
Electrohydraulically released	E
Automatic adjustment to accommodate friction block wear	A
Thrusters 451, 452 or 453 are available	451 452 453
Material: steel	ST

Example for ordering

Brake Caliper DT 250 FEA, thruster 452, material: steel

DT 250 FEA - 452 - ST

Technical Data

	Brake Caliper DT 250 FEA ... ST		
	with thruster 451	with thruster 452	with thruster 453
Brake drum diameter	Braking torque	Braking torque	Braking torque
mm	Nm	Nm	Nm
250	300	400	750
Clamping force	3000 N	4000 N	7500 N
Braking torque adjustable (optional)	20 - 100%	20 - 100%	20 - 100%
Nominal power	130 W	180 W	240 W
Oil volume	1,4 l	2,5 l	3,5 l
Voltage	230/400 V	230/400 V	230/400 V
Weight	40 kg	45 kg	47 kg

The braking torques shown in the table are based on a theoretical friction coefficient of 0,4.

Brake Caliper DT 250 FEA ... ST

spring activated – electrohydraulically released
 Drum Brake according to DIN 15 435

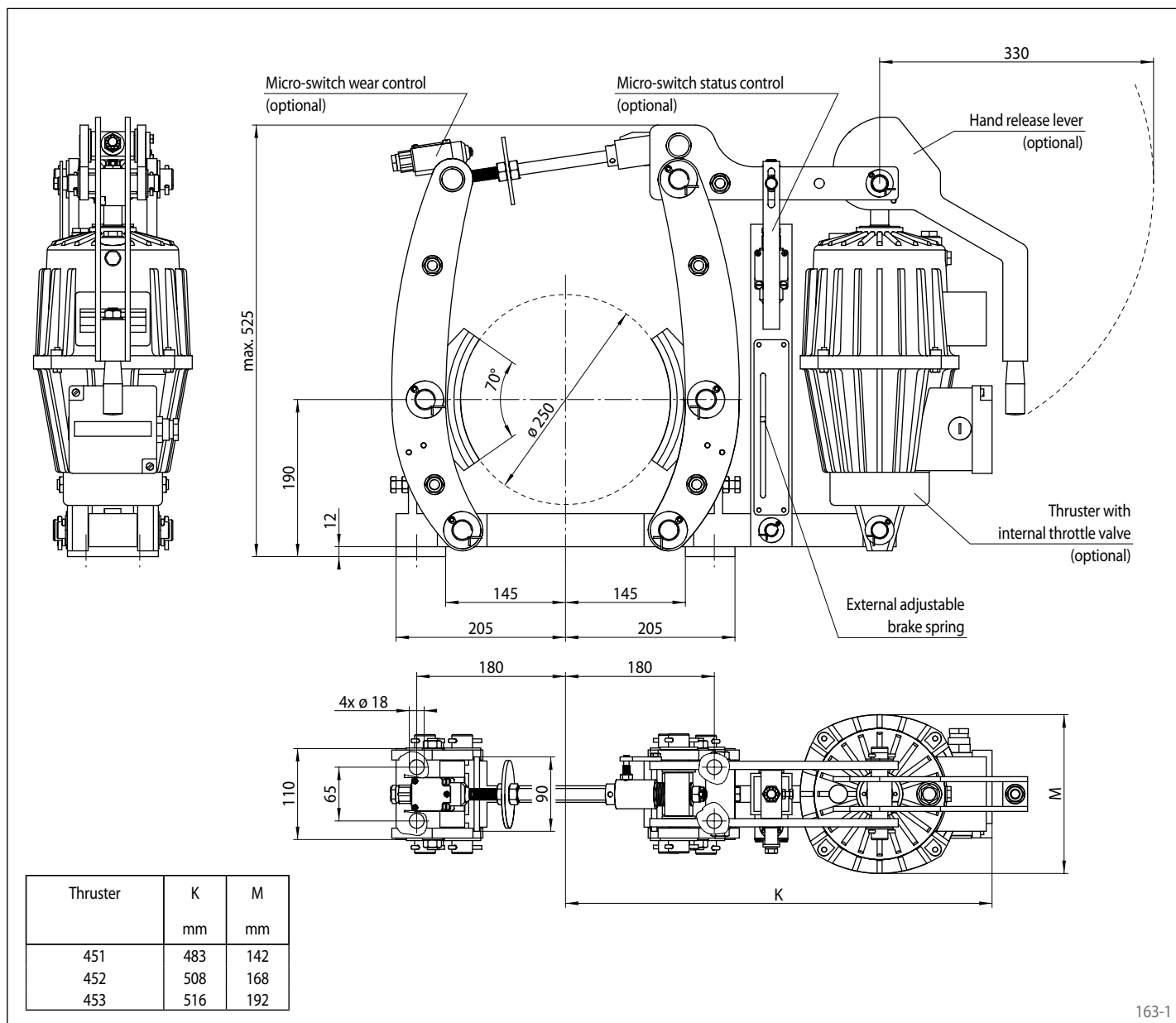

163-1

Options

- Micro-switch wear control
- Micro-switch status control
- Hand release lever
- Thruster with internal throttle valve
- Thruster in heat resistant design
- Corrosion protected design
- Wider brake shoes and brake drums